

HWD

series



Waterflow Detector with Retard – U Bolted

- Service Pressure: Up to 300PSI
- Flow Sensitivity Range for Signal: 4-10GPM (15.0-37.5L/min)
- Maximum Surge: 18FPS (5.5m/s)
- Contact Ratings: Two sets of SPDT
 - 10.1Amps at 125/250 VAC
 - 2.0Amps at 24 VDC
- Operating Temperature Range: 40° F to 120°F (4.5°C to 49°C)
- Enclosure Rating: NEMA 4- suitable for indoor/outdoor use
- Conduit Entrances: Two opening for 1/2" conduit
 - One open, one knock-out type
- Compatible Pipe: Steel water pipe, schedule 10 through 40
- Service Use: Automatic Sprinkler: NFPA-13
- One or Two Family Dwelling: NFPA-13D
- Residential Occupancies up to 4 stories: NFPA-13R
- National Fire Alarm Code: NFPA-72
- Warranty: 3 Years



HWD

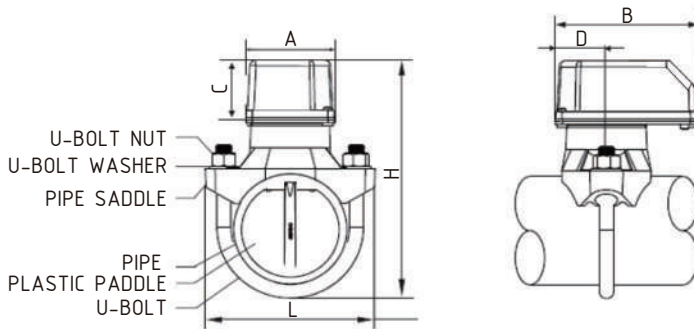
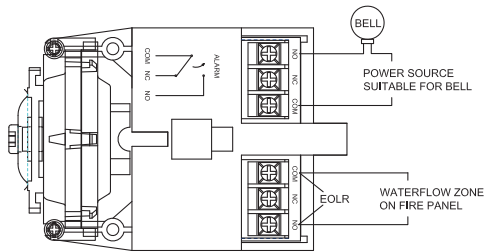

ITEM	PARTS	MATERIAL
1	SADDLE	ALUMINUM ADC12
2	PLATE	ALUMINUM ADC12
3	COVER	PLASTIC
4	PADDLE	PLASTIC
5	MICROSWITCH	PLASTIC
6	GASKET	EPDM
7	RETARD DEVICE	PLASTIC
8	TERMINAL BLOCK	PLASTIC

SIZES		DIMENSIONS (MM)						
Inch	mm	L	H	A	B	C	D	WEIGHT(KG)
2"	DN 50	94.5	165.8	95.25	146.56	55.88	72.39	1.35
2.5"	DN 65	109.5	180.8	95.25	146.56	55.88	72.39	1.35
3"	DN 80	134	195.8	95.25	146.56	55.88	72.39	1.4
4"	DN 100	154	215.8	95.25	146.56	55.88	72.39	1.45
6"	DN 150	204	265.8	95.25	146.56	55.88	72.39	1.85
8"	DN 200	254	315.8	95.25	146.56	55.88	72.39	2.42